

HIGH TEMP. SHUT OFF VALVE
ASSEMBLY

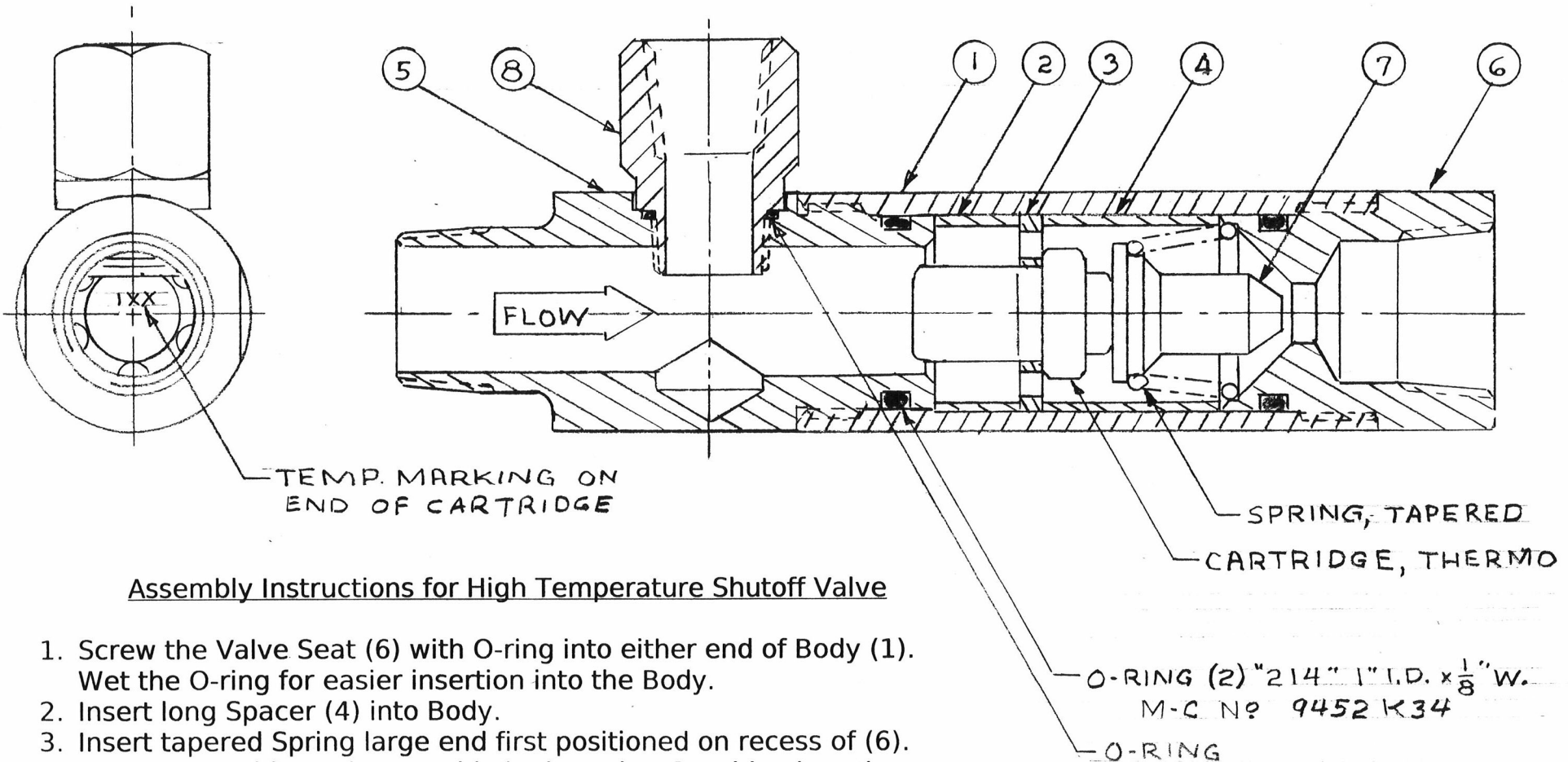

Assembly Instructions for High Temperature Shutoff Valve

1. Screw the Valve Seat (6) with O-ring into either end of Body (1). Wet the O-ring for easier insertion into the Body.
2. Insert long Spacer (4) into Body.
3. Insert tapered Spring large end first positioned on recess of (6).
4. Prepare Cartridge sub assembly by inserting Cartridge into the Cartridge Plate (3). Insert Stem of Valve and Stem Ass'y. (7) into the Cartridge.
5. Verify that the Spring is properly in place, then carefully slide the Valve/Cartridge sub assembly into the Body (1) followed by the short Spacer (2).
6. Prepare the Inlet (5) with O-rings on the Inlet (5) and Thermometer Nipple (8); assemble these two parts using appropriate thread sealant or Teflon tape.
7. Insert the Inlet and push (to compress the tapered Spring) while turning clockwise to initiate thread engagement. Tighten.