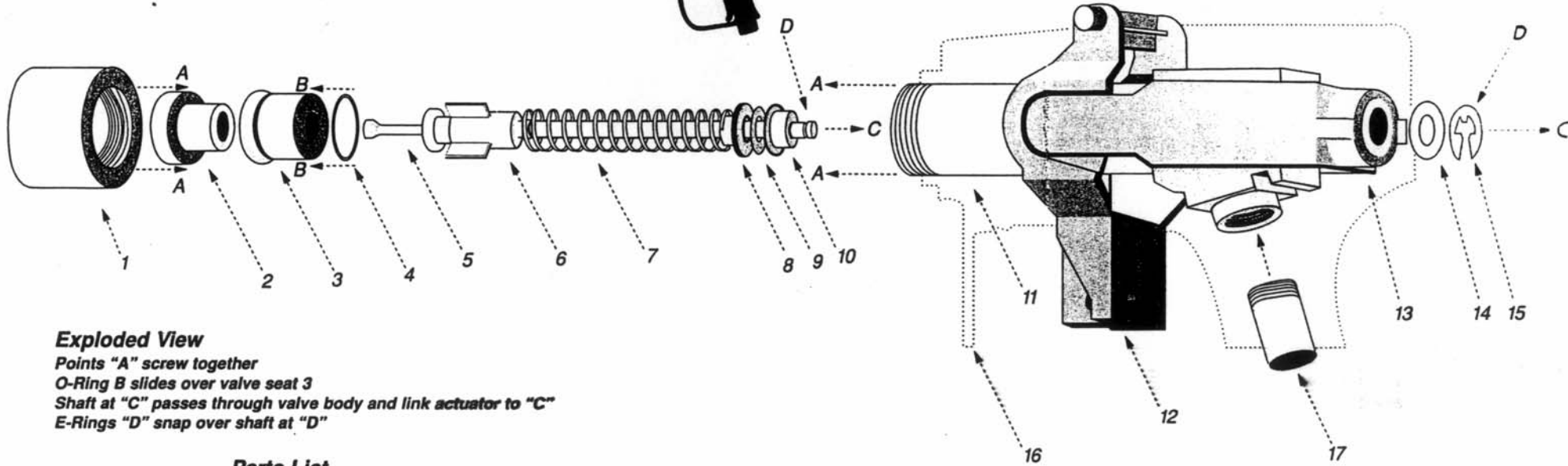

# WATER BOSS™

## Exploded View

Points "A" screw together

O-Ring B slides over valve seat 3

Shaft at "C" passes through valve body and link actuator to "C"

E-Rings "D" snap over shaft at "D"

## Parts List

1 - Nozzle Shroud	10 - Valve Stem Bushing
2 - Nozzle*	11 - Valve Body
3 - Valve Seat	12 - Trigger
4 - "O"-Ring	13 - Link Actuator
5 - Valve Stem	14 - Stainless Steel Washer
6 - Valve Guide	15 - "E"- Ring (2 required)
7 - Stainless Steel Spring	16 - Housing
8 - Spring Guide	17 - Inlet Pipe
9 - "O"-Ring	

Water Boss long trigger (750-3/8-L)

Water Boss short trigger (750-3/8-S)

Repair Kit "A" contains parts 1-4 (RK-750-A)

Repair Kit "B" contains parts 1-10 & 12-16 (RK-750-B)

# ERGO TECH

Lilly Engineering Company, Inc.  
 P.O. Box 173, 217 Catalpa Street  
 Itasca, Illinois 60143-0173  
 630-773-2222 Fax: 630-773-3443